

SILENT Series

INSTALL SILENCE, INSTALL QUALITY OF LIFE



The Quietest Extractors in the World in their Category



Lp
26,5
dB

AXIAL FLOW FANS

SILENT Series



SILENT-100
SILENT-100 ECOWATT



SILENT-200



SILENT-300



SILENT-100 DESIGN 3 C
SILENT-100 DESIGN ECOWATT



SILENT-200 DESIGN 3 C

Axial flow fans for wall or ceiling installation, designed to solve ventilation problems in small rooms and bathrooms. The motors from the SILENT range are mounted on silent-elastic-blocks which absorb the vibrations. In this way not only is the noise from the extractor significantly reduced but so too is the noise from the surface which supports it. Additionally, the motors from the SILENT range are equipped with ball bearings which guarantee long life working (more than 30.000 working hours) at any shaft positions. The SILENT range consists of three different models: SILENT-100, SILENT-200 and SILENT-300, available with different integrated control options to accommodate all application requirements.

Installation examples

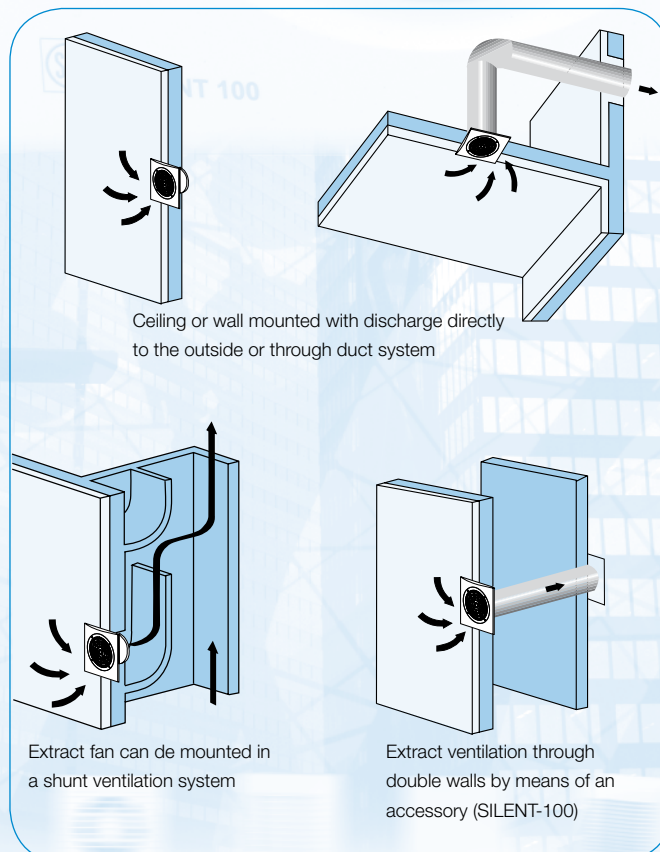

- C** All models are fitted with back draft shutter.
- Z** All models includes ball bearings greased for life (up to 30.000 hours).
- R** Model fitted with an adjustable period Run-On-Timer keeping the fan in operation for the pre set period of time after the fan has been switched off.
- H** Model with an adjustable humidistat.
- D** Model provided with a passive infra-red detector operating up to 4 m from the fan.



BATHROOM EXTRACT FANS

SILENT-100 Series



Range of axial extractors with airflow rates of approx. 95 m³/h, for connection to 100 mm diameter circular ducting.



Validated mark of approval
noise abatement society

Motor mounted on silent-elastic-blocks which absorb the vibrations and allow offering very low noise level. All the fans are manufactured from injection moulded plastic, fitted with automatic shutter and single phase 230V-50Hz, class B low consumption motor equipped with thermal overload protection. All the fans are class II insulation, **IP45** rated and suitable to operate with air temperature up to 40°C.

Lp
**26,5
dB**

Low noise!

IP45

Water protected!

consumption
8W!

Energy efficient!

SILVER versions

The SILENT-100 CZ and CRZ can be supplied with an aesthetical silver front grille.

Back draft shutter



To prevent air entry and limit heat leakage when the extractor is not operating. It opens due to the pressure of the air

Silent-blocks



Motor mounted on "Silent-elastic-block" to prevent vibration and noise transmission

Quiet operation

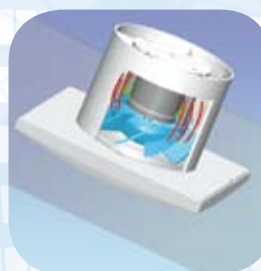

SILENT-100

In usual extract fans the vibrations are transmitted to the surrounding areas while in SILENT extractor fans the vibrations are absorbed by the Silent Blocks



Usual extractor

Models features

	CZ	CRZ	CRIZ	CHZ	CHZ VISUAL	CDZ	CZ 12V	CZ SILVER	CRZ SILVER	CHZ SILVER	CZ SILVER 12V
Pilot light	•	•	•	•	•	•	•			•	•
Backdraft shutter	•	•	•	•	•	•	•	•	•	•	•
Adjustable Run-On-Timer (1-30 min)		•		•	•	•	*		•	•	*
Automatic timer			•								
Adjustable humidistat				•	•					•	
Detector movement						•					
Ball bearings	•	•	•	•	•	•	•	•	•	•	•
Silver colour								•	•	•	•

* Using CT-12/14R transformer

Technical characteristics

Model	Speed (r.p.m.)	Abs. power at free discharge (W)	Voltage (V) 50 Hz	Sound pressure level* (dB(A))	Airflow at free discharge (m ³ /h)	Insulation/ IP	Ø duct (mm)	Weight (kg)
SILENT-100	2400	8	230	26,5	95	II / IP45	100	0,57
SILENT-100 12V	2320	13	12	26,5	95	⊕ / IP57	100	0,57

* Sound pressure level measured at 3 m at free air conditions.

Dimensions (mm)

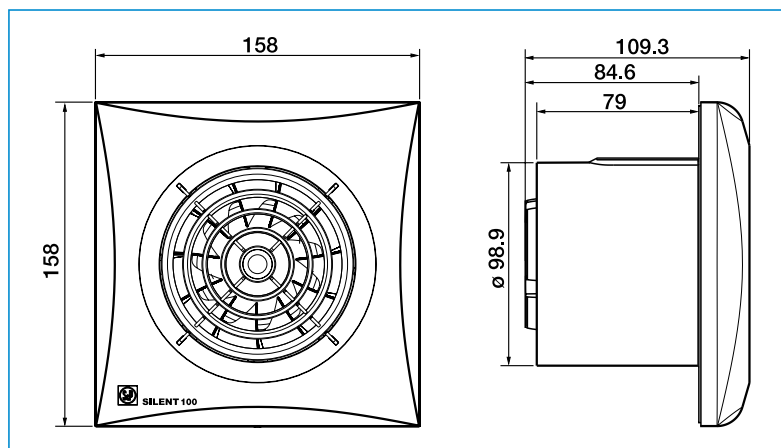

Performance curve

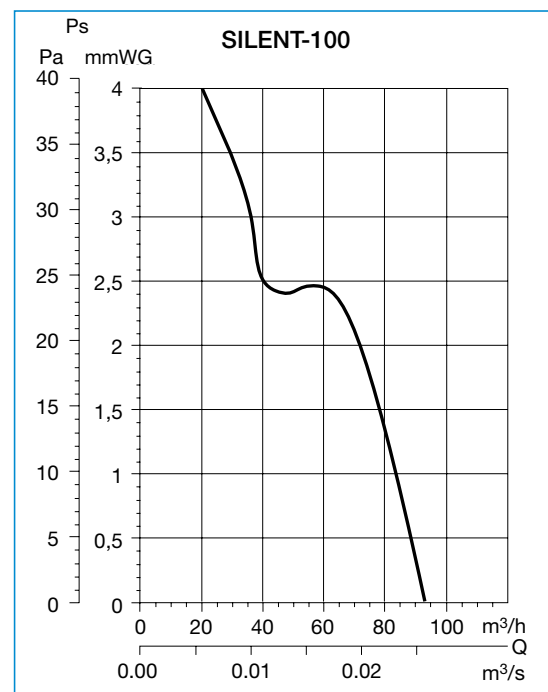

Accessories



GSA-100
Flexible aluminium ducting



GRA-70
Aluminium exterior grille



WALL KIT
Fixed shutter and telescopic duct (200 to 420 m)



CX-80/125
Worm drive ducting clip



PER-100W
Back draft shutter



WINDOW KIT

SILENT-100 models with special functions

SILENT-100

Bathroom and toilet extract fans



SILENT-100 CZ 12V
White color version

SILENT-100 CZ SILVER 12V
Version with a silver color front grille

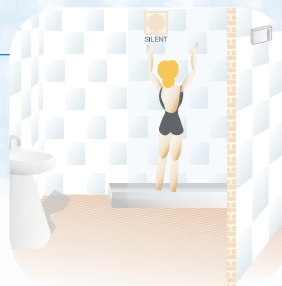

Model SELV (Safety Extra Low Voltage). Specially designed to operate within the shower or bath volume with total safety. They are rated 12V, Class III and IP57.



SILENT-100 12V must be wired to a safety isolating **transformer CT-12/14** which must be located out of the reach of the water spray or person using a bath or shower. The transformer is IP21, class II insulation and protected by fuse. Also available, **Transformer CT12/14 R**, supplied with adjustable run-on-timer between 1 to 30 minutes.

KIT SILENT-100 CZ 12V + CT

Kit integrated by an extractor SILENT-100 CZ 12V and a safety isolating transformer CT-12/14.



SILENT-100 CDZ

Model provided with a PIR (passive infra-red) detector. The unit starts automatically when a movement is detected within a maximum distance of 4 meters from the fan. They are also fitted with an adjustable "run on" timer, from 1 to 30 minutes, to allow the fan continues operating after the initiation of the movement detection.



SILENT-100 CHZ VISUAL

Models provided with an electronic humidistat which can be adjusted to 60, 70, 80 or 90% HR using a key situated on the front grille. Four luminous indicators show the desired level of humidity. The extractor operates automatically when the humidity level in the room is higher than the set level. The extractor will stop automatically when the humidity drops below the selected level and after the selected period set on the adjustable timer (1 and 30 minutes).



BATHROOM EXTRACT FANS

SILENT-100 ECOWATT Series



Validated mark of approval
noise abatement society

Range of axial extractors with airflow rates of approx. 95 m³/h, **high-performance, low-consumption** Brushless motors, for connection to 100 mm diameter circular ducting.

Motor mounted on **silent-elastic-blocks** which absorb the vibrations and allow offering very low noise level. All the fans are manufactured from injection moulded plastic, fitted with automatic shutter and single phase 230V-50/60Hz, low consumption motor equipped with thermal overload protection. All the fans are class II insulation, IP45 rated and suitable to operate with air temperature up to 40°C.

With consumption of only 5W, the SILENT ECOWATT series extractors are especially recommended toilets, bathrooms and installations **where the extractor will require long working hours** resulting in a considerable reduction in energy costs.



ENERGY EFFICIENT



VENTILATION SYSTEM

Lp
26,5 dB

Low noise!

IP45

Water protected!

consumption
5W!

Energy efficient!

Back draft shutter



To prevent air entry and limit heat leakage when the extractor is not operating. It opens due to the pressure of the air

Silent-blocks



Motor mounted on **"Silent-elastic-block"** to prevent vibration and noise transmission

Quiet operation

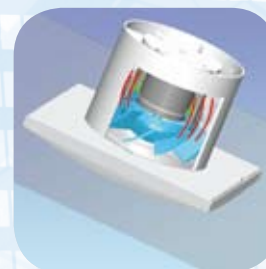

SILENT-100 ECOWATT

In usual extract fans the vibrations are transmitted to the surrounding areas while in SILENT extractor fans the vibrations are absorbed by the Silent Blocks

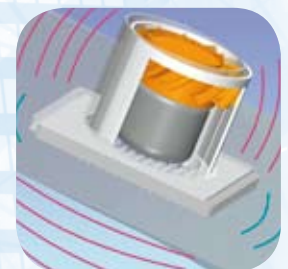

Usual extractor

Models features

	CZ	CRZ	CHZ	CDZ	CZ SILVER	CRZ SILVER	CHZ SILVER	CDZ SILVER
DC motor	•	•	•	•	•	•	•	•
Pilot light	•	•	•	•	•	•	•	•
Backdraft shutter	•	•	•	•	•	•	•	•
Adjustable Run-On-Timer		•	•	•		•	•	•
Adjustable humidistat			•				•	
Detector movement				•				•
Silver colour					•	•	•	•

Technical characteristics

Model	Speed (r.p.m.)	Abs. power at free discharge (W)	Voltage (V) 50 Hz	Sound pressure level* (dB(A))	Airflow at free discharge (m ³ /h)	Insulation/ IP	Ø duct (mm)	Weight (Kg)
SILENT-100 ECOWATT	2100	5	230	26,5	95	II / IP45	100	0,57

* Sound pressure level measured at 3 m at free air conditions.

Performance curve

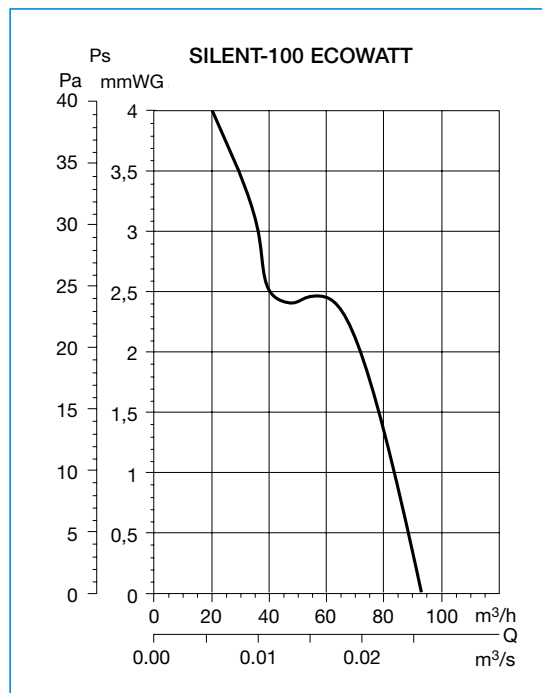

Dimensions (mm)

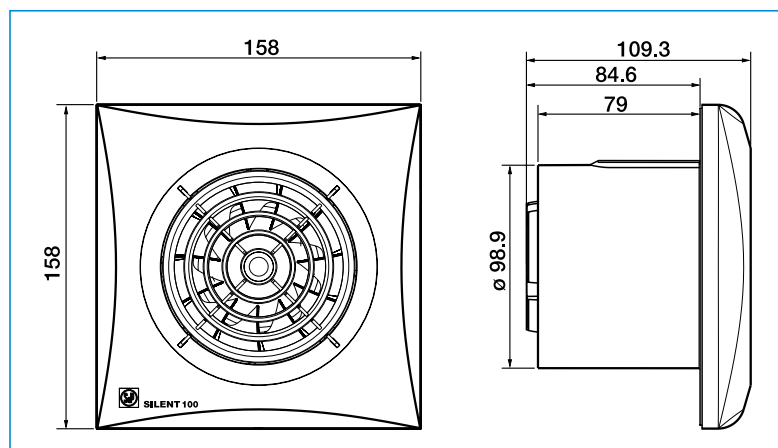

Accessories



GSA-100
Flexible aluminium
ducting



GRA-70
Aluminium
exterior grille



Fixed shutter and
telescopic duct
(200 to 420 m)



CX-80/125
Worm drive ducting
clip



PER-100W
Back draft
shutter



WINDOW KIT



BATHROOM EXTRACT FANS

SILENT-200 Series



Range of axial extractors with airflow rates of approx. 180 m³/h, for connection to 120 mm diameter circular ducting.

Motor mounted on silent-elastic-blocks which absorb the vibrations and allow offering very low noise level. All the fans are manufactured from injection moulded plastic, fitted with automatic shutter and single phase 230V-50Hz, class B low consumption motor equipped with thermal overload protection. All the fans are class II insulation, **IP45** rated and suitable to operate with air temperature up to 40°C.

The SILENT-200 CZ and CRZ can be supplied with an aesthetical silver front grille.

IP45



The SILVER versions are supplied with an aesthetical silver front grille.

SILENT-200

Bathroom and toilet extract fans

Back draft shutter



To prevent air entry and limit heat leakage when the extractor is not operating. It opens due to the pressure of the air

Silent-blocks



Motor mounted on "Silent-elastic-block" to prevent vibration and noise transmission

Quiet operation

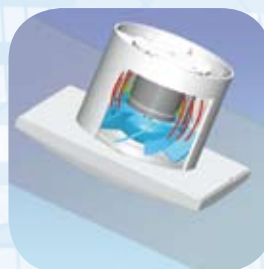

SILENT-200

In usual extract fans the vibrations are transmitted to the surrounding areas while in SILENT extractor fans the vibrations are absorbed by the Silent Blocks



Usual extractor



Models features

	CZ	CRZ	CHZ	CZ SILVER	CRZ SILVER	CHZ SILVER
Pilot light	•	•	•	•	•	•
Backdraft shutter	•	•	•	•	•	•
Adjustable Run-On-Timer (1-30min)		•	•		•	•
Adjustable humidistat			•			•
Ball bearings	•	•	•	•	•	•
Silver colour				•	•	•

Technical characteristics

Model	Speed (r.p.m.)	Abs. power at free discharge (W)	Voltage (V) 50 Hz	Sound pressure level* (dB(A))	Airflow at free discharge (m ³ /h)	Insulation / IP	Ø duct (mm)	Weight (kg)
SILENT-200	2350	16	230	33	180	II / IP45	120	0,77

* Sound pressure level measured at 3 m at free air conditions.

Performance curve

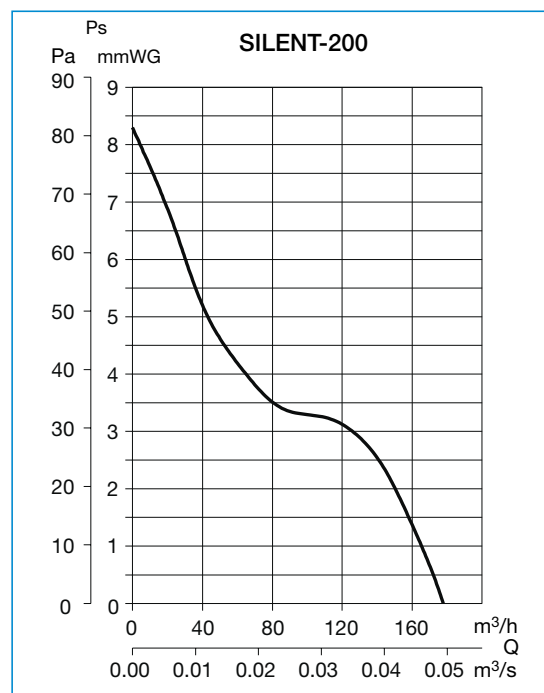

Dimensions (mm)

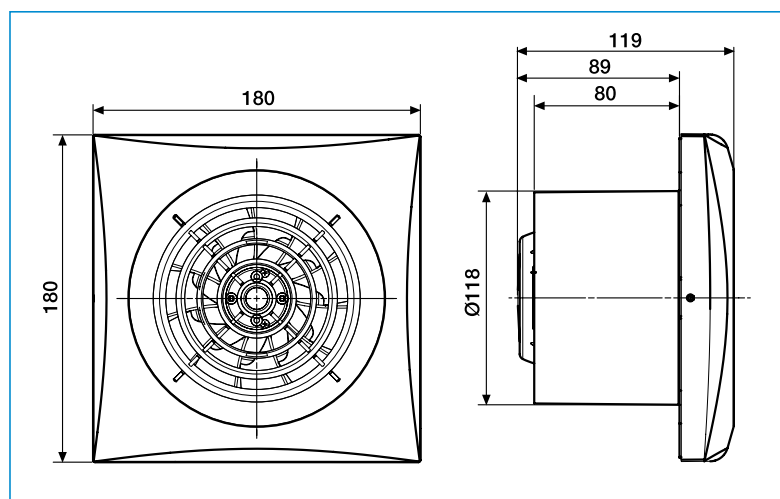

Accessories



GSA-125
Flexible aluminium ducting



GRA-150
Aluminium exterior grille



CX-125/215
Worm drive ducting clip



PER-125W
Back draft shutter



AXIAL EXTRACT FANS

SILENT-300 and SILENT-300 PLUS Series



Range of axial extractors with airflow rates of approx. 280 m³/h, for connection to 150 mm diameter circular ducting.

Motor mounted on silent-elastic-blocks (SILENT-300) which absorb the vibrations and allow offering very low noise level. All the fans are manufactured from injection moulded plastic, fitted with automatic shutter and single phase 230V-50Hz, class B low consumption motor equipped with thermal overload protection. All the fans are class II insulation, **IP45** rated and suitable to operate with air temperature up to 40°C.

The SILENT-300 CZ and CRZ can be supplied with an aesthetical silver front grille.

IP45



The SILVER versions are supplied with an aesthetical silver front grille.

SILENT-300

Bathroom and toilet extract fans

Back draft shutter



To prevent air entry and limit heat leakage when the extractor is not operating. It opens due to the pressure of the air

Silent-blocks



Motor mounted on "Silent-elastic-block" to prevent vibration and noise transmission (SILENT-300)

Quiet operation

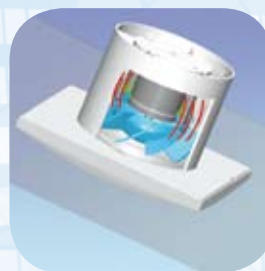

SILENT-300

In usual extract fans the vibrations are transmitted to the surrounding areas while in SILENT extractor fans the vibrations are absorbed by the Silent Blocks

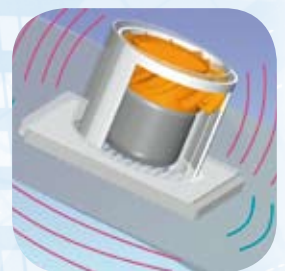

Usual extractor

Models features

	CZ	CRZ	CHZ	CZ SILVER	CRZ SILVER	CHZ SILVER
Pilot light	•	•	•	•	•	•
Backdraft shutter	•	•	•	•	•	•
Adjustable Run-On-Timer (1-30min)		•	•		•	•
Adjustable humidistat			•			•
Ball bearings	•	•	•	•	•	•
Silver colour				•	•	•

Technical characteristics

Model	Speed (r.p.m.)	Abs. power at free discharge (W)	Voltage (V) 50 Hz	Sound pressure level* (dB(A))	Airflow at free discharge (m³/h)	Insulation / IP	Ø duct (mm)	Weight (kg)
SILENT-300	1700	29	230	32	280	II / IP45	150	1,25
SILENT-300 PLUS	2000	21	230	36	320	II / IP45	150	1,65

* Sound pressure level measured at 3 m at free air conditions.

Dimensions (mm)

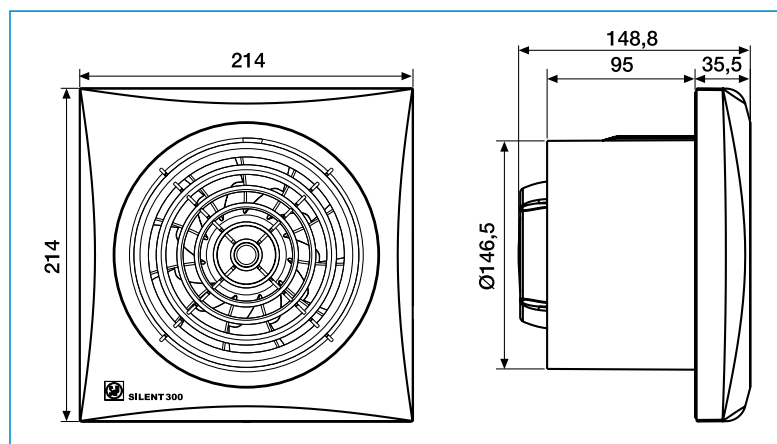

Performance curve

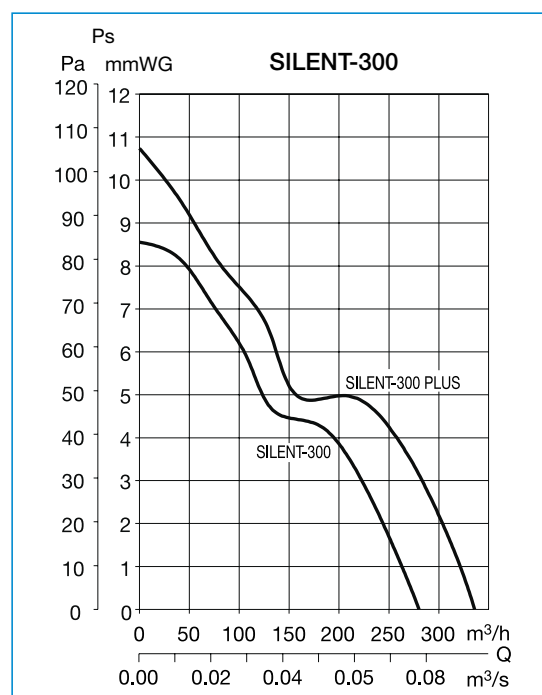

Accessories



GSA-150
Flexible aluminium ducting



GRA-150
Aluminium exterior grille



PER-160W
Back draft shutter



CX-125/215
Worm drive ducting clip



REB
Single phase electronic speed controllers



BATHROOM EXTRACT FANS

SILENT-100 DESIGN 3C Series



Range of axial extractors with airflow rates of approx. 85 m³/h, for connection to 100 mm diameter circular ducting.

Motor mounted on silent-elastic-blocks which absorb the vibrations and allow offering very low noise level. All the fans are manufactured from injection moulded plastic, fitted with automatic shutter and single phase 230V-50Hz, class B low consumption motor equipped with thermal overload protection. All the fans are class II insulation, **IP45** rated and suitable to operate with air temperature up to 40°C.

Lp
**26,5
dB**

IP45

consumption
8W!

Diferent colours available on request



Black

Gold

Grey

Champagne



Silver

Red

Marble white

Marble black

Back draft shutter



To prevent air entry and limit heat leakage when the extractor is not operating. It opens due to the pressure of the air.

Silent-blocks



Motor mounted on "Silent-elastic-block" to prevent vibration and noise transmission.

Quiet operation

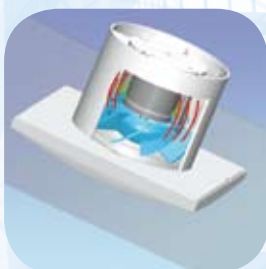

SILENT-100 Design

In usual extract fans the vibrations are transmitted to the surrounding areas while in SILENT extractor fans the vibrations are absorbed by the Silent Blocks.



Usual extractor

Models 3C



Interchangeable bars colours let the fan blend in with every setting. 4 colours to match the decor of the room: blue, red, green and yellow.

Models features

	CZ DESIGN 3C	CRZ DESIGN 3C	CHZ DESIGN 3C	CZ SILVER DESIGN 3C	CRZ SILVER DESIGN 3C	CHZ SILVER DESIGN 3C
Pilot light	•	•	•	•	•	•
Backdraft shutter	•	•	•	•	•	•
Adjustable Run-On-Timer (1-30min)		•	•		•	•
Adjustable humidistat			•			•
Ball bearings	•	•	•	•	•	•
Silver colour				•	•	•
kit bar lights 4 colours	•	•	•	•	•	•

Technical characteristics

Model	Abs. power at free discharge (W)	Voltage (V) 50 Hz	Sound pressure level* (dB(A))	Airflow at free discharge (m ³ /h)	Insulation/ IP	Ø duct (mm)	Weight (kg)
SILENT-100 DESIGN 3C	8	230	26,5	85	II / IP45	100	0,65
KIT SILENT-100 DESIGN 12V** 3C	12	12	26,5	80	III / IP57	100	0,65

* Sound pressure level measured at 3 m at free air conditions.

** Delivered with CT-12/14 transformer.

Dimensions (mm)

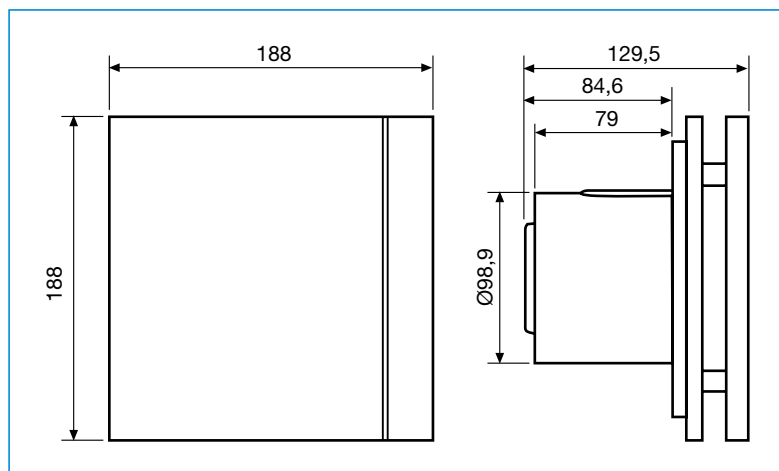

Performance curve

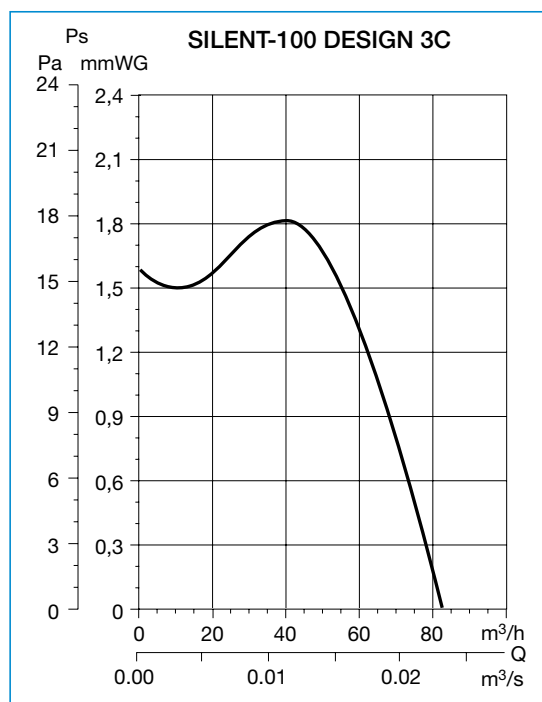

Accessories



GSA-100
Flexible aluminium ducting



GRA-70
Aluminium exterior grille



WALL KIT
Fixed shutter and telescopic duct (200 to 420 m)



CX-80/125
Worm drive ducting clip



PER-100W
Back draft shutter



WINDOW KIT

BATHROOM EXTRACT FANS

SILENT-100 DESIGN

ECOWATT Series



Validated mark of approval
noise abatement society

Range of axial extractors with airflow rates of approx. 85 m³/h, high-performance, low-consumption Brushless motors, for connection to 100 mm diameter circular ducting.

Motor mounted on **silent-elastic-blocks** which absorb the vibrations and allow offering very low noise level. All the fans are manufactured from injection moulded plastic, fitted with automatic shutter and single phase 230V-50/60Hz, low consumption motor equipped with thermal overload protection. All the fans are class II insulation, IP45 rated and suitable to operate with air temperature up to 40°C.

With **consumption of only 5W**, the SILENT ECOWATT series extractors are especially recommended toilets, bathrooms and installations **where the extractor will require long working hours** resulting in a considerable reduction in energy costs.

ENERGY EFFICIENT



VENTILATION SYSTEM

Lp
26,5 dB

Low noise!

IP45

Water protected!

consumption
5W!

Energy efficient!

Back draft shutter



To prevent air entry and limit heat leakage when the extractor is not operating. It opens due to the pressure of the air

Silent-blocks



Motor mounted on **"Silent-elastic-block"** to prevent vibration and noise transmission

Quiet operation

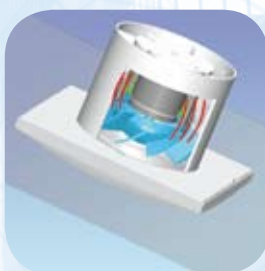

SILENT-100 ECOWATT DESIGN Usual extractor
In usual extract fans the vibrations are transmitted to the surrounding areas while in SILENT extractor fans the vibrations are absorbed by the Silent Blocks

Models 3C



Interchangeable bars colours let the fan blend in with every setting. 4 colours to match the decor of the room: blue, red, green and yellow.

Models features

	CZ	CRZ	CHZ	CZ SILVER	CRZ SILVER	CHZ SILVER
DC motor	•	•	•	•	•	•
Pilot light	•	•	•	•	•	•
Backdraft shutter	•	•	•	•	•	•
Adjustable Run-On-Timer		•	•		•	•
Adjustable humidistat			•			•
Silver colour				•	•	•

Technical characteristics

Model	Speed (r.p.m.)	Abs. power at free discharge (W)	Voltage (V) 50 Hz	Sound pressure level* (dB(A))	Airflow at free discharge (m ³ /h)	Insulation/ IP	Ø duct (mm)	Weight (Kg)
SILENT-100 DESIGN ECOWATT	2100	5	230	26,5	85	II / IP45	100	0,65

* Sound pressure level measured at 3 m at free air conditions.

Performance curve

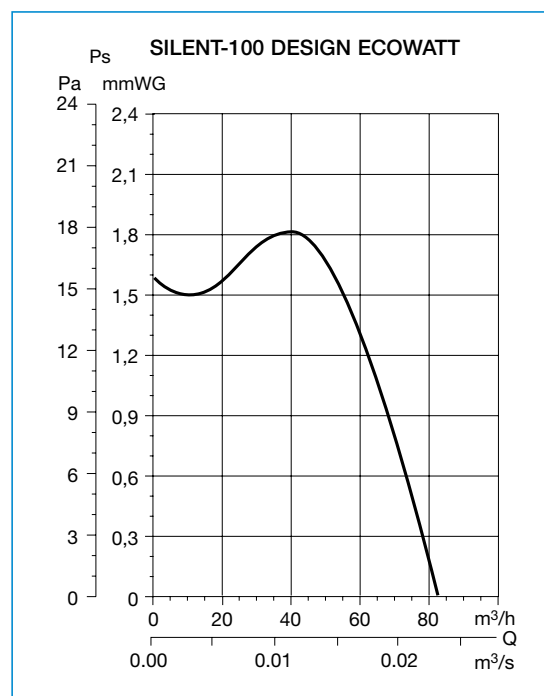

Dimensions (mm)

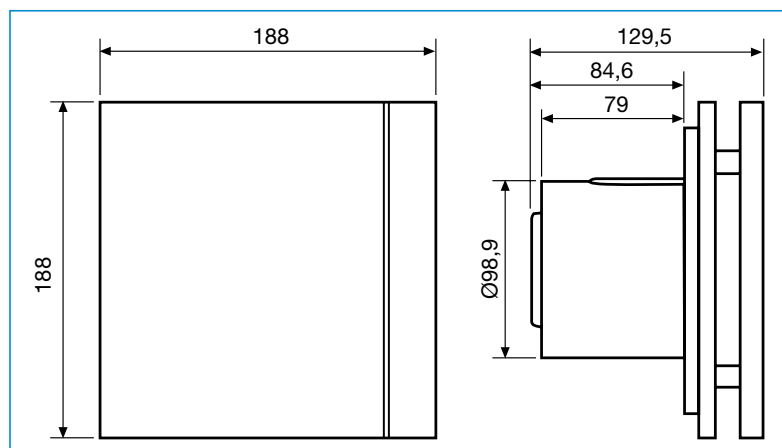

Accessories



GSA-100
Flexible aluminium ducting



GRA-70
Aluminium exterior grille



Fixed shutter and telescopic duct (200 to 420 m)



CX-80/125
Worm drive ducting clip



PER-100W
Back draft shutter



WINDOW KIT



BATHROOM EXTRACT FANS

SILENT-200 DESIGN 3C Series



Range of axial extractors with airflow rates of approx. 175 m³/h, for connection to 120 mm diameter circular ducting.

Motor mounted on silent-elastic-blocks which absorb the vibrations and allow offering very low noise level. All the fans are manufactured from injection moulded plastic, fitted with automatic shutter and single phase 230V-50Hz, class B low consumption motor equipped with thermal overload protection. All the fans are class II insulation, **IP45** rated and suitable to operate with air temperature up to 40°C.

Lp
35
dB

IP45

consumption
16W!



Different styles with the bars colours.

SILVER versions can be supplied with an aesthetical silver front grille.

SILENT-200 DESIGN 3C

Bathroom and toilet extract fans

Back draft shutter



To prevent air entry and limit heat leakage when the extractor is not operating. It opens due to the pressure of the air.

Silent-blocks



Motor mounted on "Silent-elastic-block" to prevent vibration and noise transmission.

Quiet operation

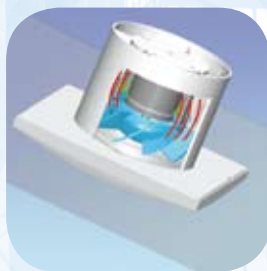

SILENT-200 DESIGN-3C

In usual extract fans the vibrations are transmitted to the surrounding areas while in SILENT extractor fans the vibrations are absorbed by the Silent Blocks.



Usual extractor

Models 3C



Interchangeable bar lights let the fan blend in with every setting. 4 colours to match the decor of the room: blue, red, green and yellow.

Models features

	CZ DESIGN 3C	CRZ DESIGN 3C	CHZ DESIGN 3C	CZ SILVER DESIGN 3C	CRZ SILVER DESIGN 3C	CHZ SILVER DESIGN 3C
Pilot light	•	•	•	•	•	•
Backdraft shutter	•	•	•	•	•	•
Adjustable Run-On-Timer (1-30min)		•	•		•	•
Adjustable humidistat			•			•
Ball bearings	•	•	•	•	•	•
Silver colour				•	•	•
kit bars 4 colours	•	•	•	•	•	•

Technical characteristics

Model	Abs. power at free discharge (W)	Voltage (V) 50 Hz	Sound pressure level* (dB(A))	Airflow at free discharge (m³/h)	Insulation / IP	Ø duct (mm)	Weight (kg)
SILENT-200 DESIGN 3C	16	230	35	175	II / IP45	120	0,88

* Sound pressure level measured at 3 m at free air conditions.

Dimensions (mm)

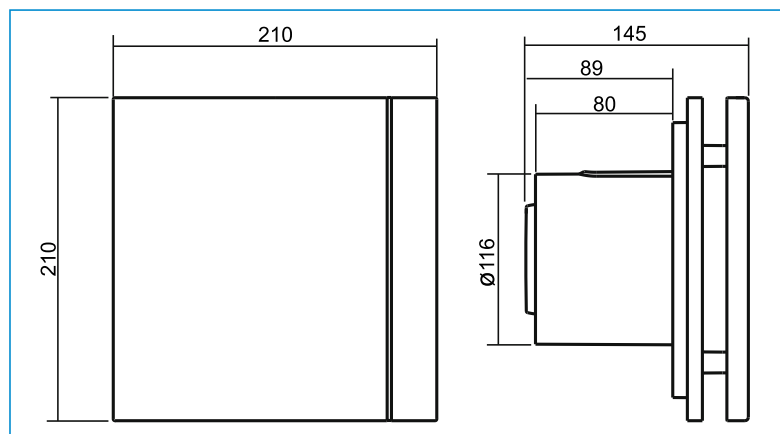

Performance curve

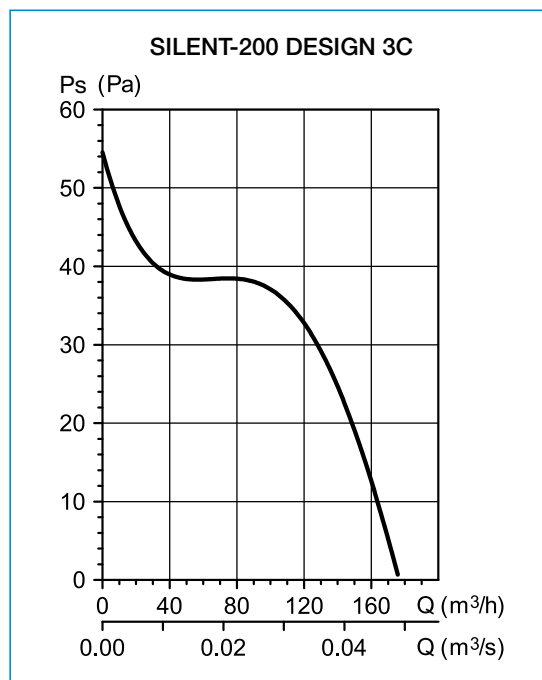

Accessories



GSA-100
Flexible aluminium ducting



GRA-70
Aluminium exterior grille



CX-80/125
Worm drive ducting clip



PER-100W
Back draft shutter